

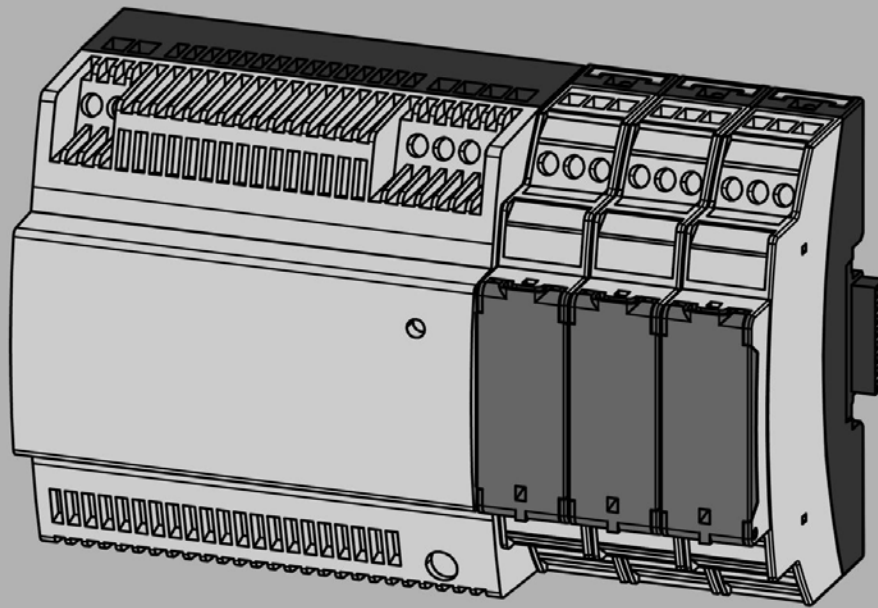

Baier[®]

Bewegende Licht- und Schattenelemente

INSTRUCTIONMANUAL



24V motor control device for DIN-rail mounting

Product group:	shutters, sliding windows, sliding shutters
Version:	1.0
Language: Orig.	english
Language:	german (deutsch)
Document:	-----



Imprint

Baier GmbH
Reiersbacher Straße 28
D-77871 Renchen-Ulm
Germany

+49 (0) 78 43 / 94 76 - 0
+49 (0) 78 43 / 94 76 - 33

info@baier-gmbh.de
www.baier-gmbh.de

Document information

Document type: Instruction manual
Title: 24V motor control device for DIN-rail mounting
Product group: sliding shutters, sliding windows, shutters
Version: 1.0
Language: english
Original Language: german(deutsch)
Document: -----

Copyright notice

This is a copyrighted document. It is not allowed to copy it fully or partly, distribute it or use it without authority, if the permission of the above mentioned originator is missing. All rights about the drawings and other documents and the power of disposal is with the originator, also in the case of application for industrial property.

Declaration of conformity

This product fulfills the basic requirements of the applicable European Directives. The conformity was detected. The original of the Declaration of conformity is available as a separate document from the manufacturer.

Technical subjects to change

Our products are always under further development and get improved. The data used for this document represents the state of the product at the time of the creation of this document.

Changings of technical details are excepted. Please use the latest version of the document and contact the manufacturer in case of doubt.



Table of content

<u>1</u>	<u>About this document</u>	4
	1.1. Target group	4
	1.2 Objective of this document	4
	1.3 Reference to other documents, guidelines and standards	4
	1.4 Used Symbols	5
<u>2</u>	<u>Safety</u>	6
	2.1 Requirements for operation	6
	2.1.1 Environmental conditions	6
	2.2 Proper use	6
	2.3 Behavior in case of an error	6
<u>3</u>	<u>Functional description</u>	7
<u>4</u>	<u>Wiring</u>	8
	4.1 Wiring diagram	8
	4.2 Wiring requirements	8
<u>5</u>	<u>Mounting and electrical connection</u>	9
	5.1 Mounting on DIN-rail or on flat surfaces	9
	5.2 Dismounting of control device	10
	5.3 Selection and mounting of power supply	10
	5.4 Electrical connection	12
	5.4.1 Terminal assignment of motor control device	12
	5.4.2 Connection of multiple motor control devices	13
	5.4.3 Use of DIN-rail connectors	14
	5.4.4 Connect multiple DIN-rail connectors in separate rows	15
<u>6</u>	<u>Initial operation</u>	16
	6.1 Configuration	17
	6.1.1 Tolerance of power operated shutdown	17
	6.1.2 Configuration switch	18
	6.2 Steps during initial operation	19
<u>7</u>	<u>Group control device</u>	20
	7.1 Functional description	20
	7.2 Electrical connection	21
	7.2.1 Terminal assignment of the group control device	21
	7.3 Initial operation	22
	7.3.1 Configuration	22
	7.3.2 Steps during initial operation	23
	7.3.3 Application example	23
	7.4 Extended functions	24
	7.4.1 Standby mode and normal operation	24
	7.4.2 Manual control mode	24
	7.4.3 Initial operation in groups	25
	7.4.4 Error mode	25



1 About this document

1.1 Target group

This document addresses qualified personnel. Mounting is only done by technical educated, trained and qualified personnel. Electrical wirings are only done by the specialist.

This document has to be accessible for the executor, has to be understood and used.

1.2 Objective of this document

This document contains important information for mounting and wiring the product. This document has to be read before all working, handed and explained to the operator as well as kept available all the time as a part of the product.

1.3 Reference to other documents, guidelines and standards

Additional documents like guidelines, standards and laws for product of this art, have to be considered.



Hint

The fabricator has an increased duty to advise the customer. The relevant guidelines, standards and laws have to be considered.



1.4 Used Symbols



Hint

A hint gives important and additional information.

NOTICE

Description of type and source of hazards

Warnings, marked with this symbol, are related to safety.

Disregard may result in property damage.

➤ Steps to avoid hazards.

CAUTION



Description of type and source of hazards

This symbol indicates a hazardous situation which, if not avoided, could result in minor or moderate injury and/or property damage.

The following levels of warning show the severity and probability of possible hazards, in ascending order.

- CAUTION, coloured yellow
- WARNING, coloured orange
- DANGER, coloured red

➤ Steps to avoid hazards.

- symbolizes a list with no specific order

List

1. symbolizes a list or instruction in specific order

- symbolizes an action
- symbolizes a reference
- ✓ symbolizes the result of the action

Instruction



2 Safety

DANGER



Electric Shock

Danger to life and health due to electrical shock.

- Electrical connections have to be installed by approved personnel only
- Switch off power before carrying out work and secure power against being switched on.
- Observe relevant safety instructions.

2.1 Requirements for operation



Hint

Read the instruction manual before performing the initial operation.

2.2 Environmental conditions

The 24V motor control device for DIN-rail mounting is designed for control cabinets in dry interior.

2.3 Proper use

This product is a motor control device for 24V DC motors of the manufacturer. It must be powered by an external 24V power supply. It allows connection to on site switches (0 / Open / Close).

The manufacturer's instructions must be observed, in especially maximum and minimum dimensions and maximum weight of the driven wing.

Any other use of this product is considered inappropriate use.

It is not guaranteed, that this product works with motors or other electronic devices of other manufacturers.

2.4 Behavior in case of an error

In case of an error, the device must be shut down and the manufacturer must be informed.

Shut down

- Do not operate device
- Disconnect device from power supply
- Inform the manufacturer



3 Functional description

The motor control device is designed for operation with a 24V DC motor. The motor usually drives a sliding door or a sliding shutter, to which it is connected by a timing belt. The motor control device is controlled by potential free inputs (0 / Open / Close).

Motor control device

The control device provides the possibility to set up different parameters via a potentiometer and a DIP-switch with 6 channels. For initial operation a reset switch is available. LEDs at the front of the control device display operation information.

Display and settings

The control device can be operated in semiautomatic mode or as deadman's control:

Operation modes

- In semiautomatic mode, the drive operates as long as no obstruction is detected or the end is not reached, even if the control signal is no longer applied.
- In deadman's control mode, the drive operates as long as no obstruction is detected or the end is not reached, but it stops instantly, when the control signal is removed.

The maximum speed can be chosen during initial operation.

When the control device is correctly installed and the initial operation is done, the control device drives the connected 24V DC motor. When the motor current raises above a limit, the control device shuts down the motor. This is called power operated shutdown, because by limiting the motor current, the motor torque is also limited. In this way, the control device recognizes obstructions and switches off the motor.

Power operated shutdown

The power operated shutdown is also used to recognize the end positions. Because the current consumption of the motor rises, when it reaches the end position, the control device shuts the motor down.

During initial operation, the control device measures the duration of a normal cycle. A short time before the wing reaches the end, the motor slows down. This reduces mechanical wear and increases safety. The control device can also be operated generally in slow speed.

Low Speed

The motor control device needs a 24V DC power supply, which must be provided by an external switched mode power supply.

Power supply



4 Wiring

4 Wiring

4.1 Wiring diagram

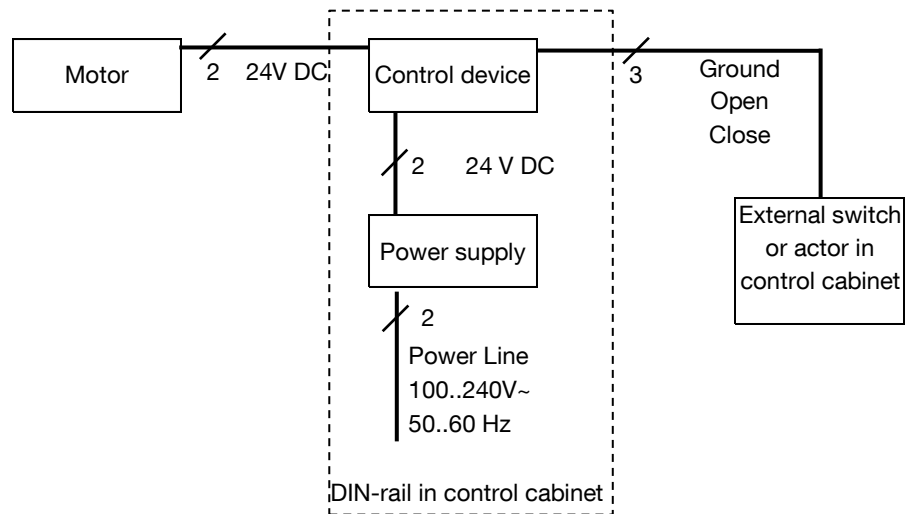

4.2 Wiring requirements

The following specifications are minimum requirements.

Wire	Type of wire
Between motor and motor control device	Motor power supply (24V =) up to 20 m: 2 x 0,50 mm ² 20 to 50 m: 2 x 0,75 mm ² 50 to 100 m: 2 x 1,50 mm ²
Between external switch and motor control device	up to 50 m: 3 x 0,25 mm ²
Between power supply and control device	Less than 1m: 2 x 1,00 mm ²

Table 1 – Wire types



5 Mounting and electrical connection

5.1 Mounting on DIN-rail or on flat surfaces

The dimensions of the motor control device comply to DIN EN 50022, to fit on DIN- rails with 35 mm width. The motor control devices width is 18 mm, which is equivalent to one modular space.



Hint

The assembly of the control cabinet, the DIN-rails, etc. has to be done on site and is not part of this document.

To mount the motor control device on a DIN-rail, lock it onto the DIN-rail. The device provides orange locking latches on its bottom side for this purpose.

Mount on DIN-rails

- Push device directly onto the DIN-rail.
- Orange locking latches snap into place.
- ✓ Motor control device is mounted.

To mount the device on a flat surface, the orange locking latches can be used to provide a mounting point.

Mount on flat surfaces

- Pull the two latches out of the control device, until they snap in a fixed position.
- Place a washer between wall and latch.
 - Outer diameter max. 8,5mm, thickness max. 1,3mm
 - e.g. lock washer M4 according to DIN 127-B
 - or crown gear according to DIN 6797
- Fix the motor control device with two screws.
 - Thread diameter max. 4 mm, head diameter max. 8,5mm
- ✓ Motor control device is mounted.

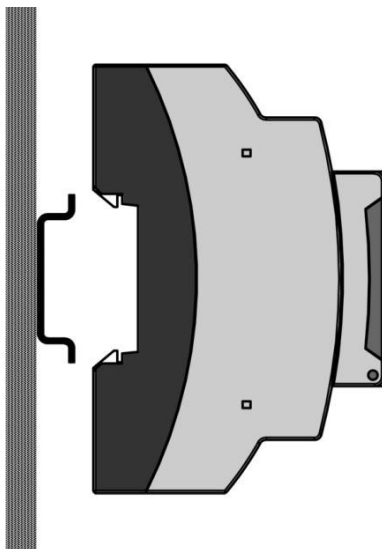

Figure 1 – Mounting on DIN-rail

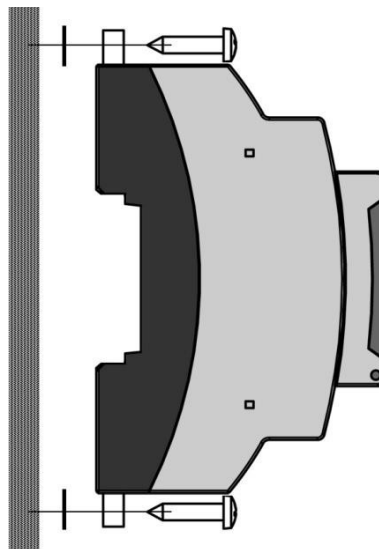

Figure 2 – Mounting on a flat surface



6 Mounting and electrical connection

5.2 Dismounting of control device

To dismount the control device, the orange locking latches must be released.

Dismount off DIN-rails

- Pull orange locking latches outside.
 - Use a flat screw driver to pull the latches.
- Pull motor control device off the DIN-rail.
- ✓ Motor control device is dismounted.

Dismount off flat surfaces

- Release screws.
- Push locking latches into control device.
- ✓ Motor control device is dismounted.

5.3 Selection and mounting of power supply

The motor control device must be powered by a power supply, which provides 24 V DC.

Select power supply

One power supply can be used for one or more motor control devices. The power of the power supply must be calculated with respect to the number and type of motors in use. The power supply must withstand peak loads, which can occur for short times during operation.

CAUTION



Inappropriate power supply

Damage of control device and/or power supply by choosing an inappropriate power supply.

- Use only power supplies, approved by the manufacturer. In case of doubt, contact manufacturer.
- Use only voltage and power values, which are specified here.
- Allow sufficient power reserves.
- Don't connect power supplies in parallel.

Technical data of power supply

The following table specifies the voltage values for one motor control device.

Parameter	Value
Input voltage	24 V DC
Input voltage tolerance	22,0 ... 26,0 V DC
Reverse voltage protection	No
Power consumption during standby	1,5 ... 2 Watt
Power consumption during activity	Depends on used motor. max. continuous: ca. 24 Watt max. peak power: ca. 30 Watt



The following table shows the power requirements of the available motors. All values are approximate values and vary, depending on the application.

Power requirement per motor

Motor	Power requirement per motor
Prometheus XS/80/MT	12 Watt (corresponds to 0,5 Ampere at 24V DC)
Prometheus XS/120/MT	18 Watt (corresponds to 0,75 Ampere at 24V DC)
Prometheus XS-2/MT	24 Watt (corresponds to 1,0 Ampere at 24V DC)

Table 2 – Power requirement per motor

The following table shows the available power supplies and the maximum power, they can provide.

Available power supply units

Article number		
11107	Prometheus XS-2/NT/UP/0,5 Power supply for flush box mounting	12 Watt, corresponds to: 1 x Prometheus XS/80/MT1 x Prometheus XS/120/MT 1 x Prometheus XS-2/MT
11108	Prometheus XS-2/NT/HS/1,75 Power supply for DIN-rail mount WxHxD: 54 x 90 x 61 mm	42 Watt, corresponds to: 3 x Prometheus XS/80/MT2 x Prometheus XS/120/MT 1 x Prometheus XS-2/MT
11109	Prometheus XS-2/NT/HS/2,5 Power supply for DIN-rail mount WxHxD: 72 x 90 x 61 mm	60 Watt, corresponds to: 5 x Prometheus XS/80/MT3 x Prometheus XS/120/MT 2 x Prometheus XS-2/MT
11110	Prometheus XS-2/NT/HS/4,2 Power supply for DIN-rail mount WxHxD: 90 x 90 x 61 mm	100 Watt, corresponds to: 8 x Prometheus XS/80/MT 5 x Prometheus XS/120/MT 4 x Prometheus XS-2/MT
11111	Prometheus XS-2/NT/HS/10 Power supply for DIN-rail mount WxHxD: 60x130x153mm	240 Watt, corresponds to: 20 x Prometheus XS/80/MT 13 x Prometheus XS/120/MT 10 x Prometheus XS-2/MT
11112	Prometheus XS-2/NT/HS/20 Power supply for DIN-rail mount WxHxD: 115x130x153mm	480 Watt, corresponds to: 40 x Prometheus XS/80/MT 26 x Prometheus XS/120/MT 20 x Prometheus XS-2/MT

Table 3 – Available power supply units

The power supply for flush box mounting (Article number 11107) must be put into a flush box.

Mount power supply

The installation of power supplies for DIN-rails is analogue to the mounting of the motor control device. Refer to chapter 5.1 - Mounting on DIN-rail or on flat surfaces for further information.



6 Mounting and electrical connection

6 Electrical connection

6.1 Terminal assignment of motor control device

The motor control device comes with three terminal blocks with 3 terminals per terminal block.

At terminals 1, 2 and 3, the power supply must be connected.

At terminals 4, 5 and 6, the potential-free control input must be connected.
(0 / Open / Close)

At terminals 7 and 9, the motor must be connected.

Klemme	Anschluss	Bild	Bild
1	Ground		
2	Ground		
3	+24V DC power supply		
4	Ground		
5	Open		
6	Close		
7	Motor 1 (+)		
8	N/A		
9	Motor 2 (-)		

Table 4 – Terminal assignment



6.2 Connection of multiple motor control devices

If more than one motor control device shall be powered by one power supply, the motor control devices must be connected in parallel.

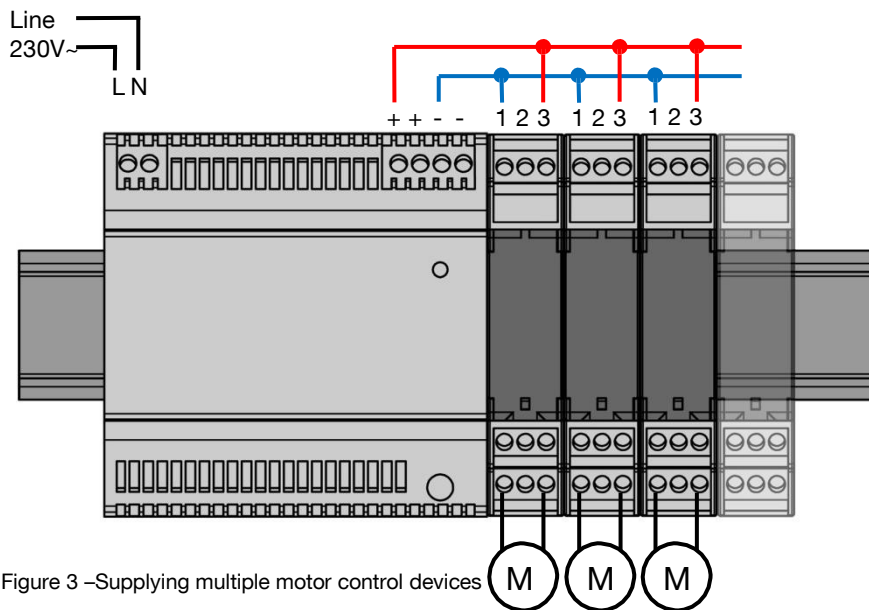

Figure 3 –Supplying multiple motor control devices

One motor control device can only drive one motor. If more than one motor is available, each motor must be driven by its own motor control device.

The control inputs (0 / Open / Close) of several motor control devices can be connected in parallel. This can be helpful, to implement grouped functionality.

CAUTION



Potential equalization

Damage of motor control device and/or power supplies through compensating currents, when control devices are driven by different power supplies.

- Connect motor control devices only to one power supply.
- Don't connect control inputs of motor control devices in parallel, when they are powered by different power supplies.



6 Mounting and electrical connection

6.3 Use of DIN-rail connectors

For easier installation, the manufacturer provides DIN-rail connectors. These can be engaged into the DIN-rail and carry both power supply voltage and control signals. Control signals are only relevant, when the group control unit is used.



Hint

When the DIN-rail connectors are used, only one motor control device must be connected to the power supply. All other motor control devices are supplied via the DIN-rail connector.

CAUTION



Cascaded DIN-rail connectors

Damage of motor control devices and/or DIN-rail connectors by too many connectors in series.

- Connect a maximum of 9 motor control devices via the DIN-rail connectors. Then begin with a new group of control devices.

Mounting of DIN-rail connectors

- Push DIN-rail connectors into DIN-rail.
- Slide DIN-rail connector to desired position.
- For connection of more DIN-rail connectors, repeat procedure and join connectors into each other.
- ✓ DIN-rail connectors are mounted.

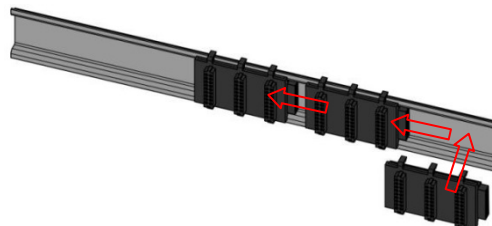

Figure 4 –Mounting DIN-rail connectors

Mounting of power supply and motor control devices

- Mounting on DIN-rail as described in chapter 5.1.
- Pins on the bottom of motor control device must have contact to the DIN-rail connector.

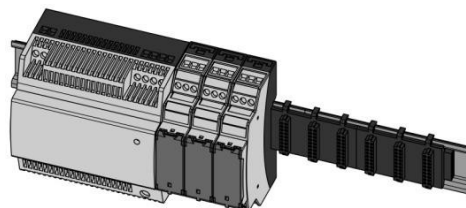

Figure 5 –Mounting devices on DIN-rail with connectors



6.4 Connect multiple DIN-rail connectors in separate rows

In some cases it may be affordable, to connect separate DIN-rails with multiple motor control devices together.

When the group control device is used (refer to chapter), but only then it is necessary to use a connector cable between different rows of DIN-rails to establish communication between the group control device and the motor control devices.

WARNING



Injury and/or property damage by electrical voltage

- Perform work on the connector cable only when it's not under voltage.
- Disconnect all power supplies, motor control devices and DIN-rail connectors from main power supply.

- Mount DIN-rail connectors
 - ➔ Refer to chapter 5.4.3
- Connect cable into last, upper DIN-rail connector.
 - ➔ Red and black wire must face upwards, blue wires must face downwards. (Refer to figure 6)
- ✓ Connector cable is installed.

Mounting of connector cable

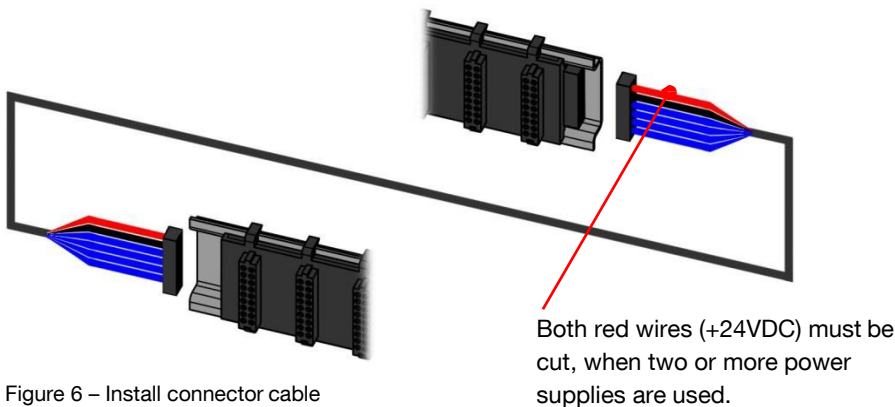

Figure 6 – Install connector cable



Hint

The connector cable transmits communication signals and power supply to the DIN-rail connectors.

If DIN-rail connectors, which are supplied by different power supply units, are connected together, the red wires (+24VDC) must be cut and removed.

- Cut and remove both red wires (+24VDC).
- ✓ Power supply wire is disconnected.

Disconnecting power supply wires



6 Initial operation

6.5 Initial operation

When the control device is mounted and electrically connected, the initial operation must be performed.

The following sections describe the parts of the control device, which are relevant for the initial operation. The following chapters describe step by step, which functions must be set up and how the initial operation is done.

The control elements are protected by a transparent cover. Open the cover in order to perform the initial operation.

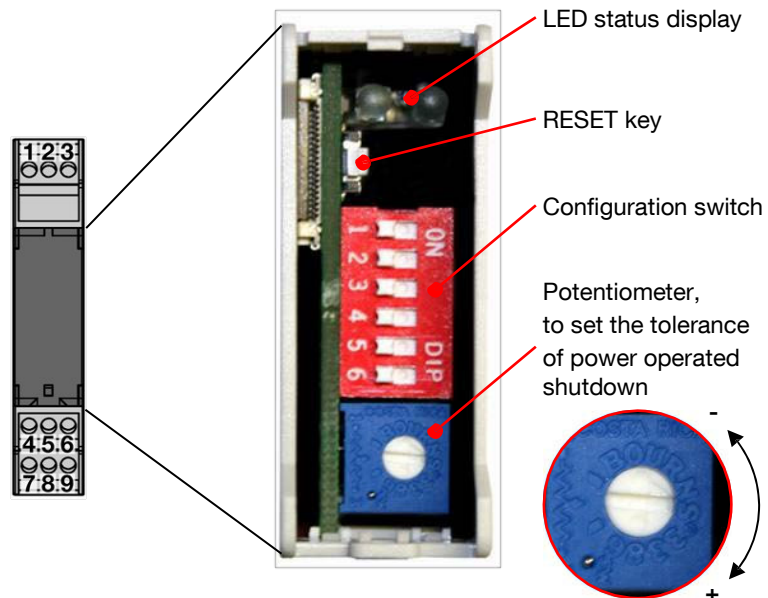



6.6 Configuration

NOTICE

Overtightened potentiometer

Damage of control device may result in malfunction.

Potentiometers have a right and a left stop, which must not be overtightened.

- Adjust potentiometer only with low force and with an appropriate screw driver.



Hint

Changes in configuration when the initial operation is done, will force the control device to perform a new initial operation.

→ Perform initial operation, refer to chapter 6.2

6.7 Tolerance of power operated shutdown

In some cases the drive will not shut down correctly during or after initial operation. Or the drive stops, before it has reached the end position. This particularly happens, when a very heavy or a very lightweight wing is used.

NOTICE

Motor overload

Damage of components by motor overload.

- Check after any change of configuration, if the control device shuts down correctly.
- Do not set tolerance too high.

When the drive stops early

- Turn potentiometer clockwise.
- ✓ Drive switches off later.

Increase tolerance

When the drive does not stop

- Turn potentiometer counterclockwise.
- ✓ Drive switches off sooner.

Decrease tolerance



Hint

After a maximum time of 5 minutes, the drive switches off in each case.



6.8 Configuration switch

	Switch	Description	OFF	ON
	1	Deadmans' control	Semi-automatic	Deadman's control
	2	Motor type	Prometheus XS/80/MT	Prometheus XS/120/MT
	3	Maximum speed	Normal	Reduced
	4	Group		
	5	Group	Refer to chapter 7 Group control device	
	6	Group		

Table 5 – Configuration switch

1. Semiautomatic function /Deadman's control
When the semiautomatic function is active, the drive is active as long as no obstruction is detected or the end position is not reached, even if the control input is not active any more.
When the deadman's control is active, the drive is active as long as no obstruction is detected or the end position is not reached, but it stops instantly, if the control input becomes inactive.
2. Motor type
Set switch according to used motor.
3. Maximum speed
Set this switch to ON, if the drive should run in reduced speed only.
4. to 6. Group membership
Define a group membership. Refer to chapter 7 for further information.



6.9 Steps during initial operation

WARNING



Moving wing

Danger of injury by squashing, shearing or collision, caused by moving wing.

- Wing moves independently during initial operation.
- Keep danger area clear during initial operation.

- Prepare electrical connections
 - Refer to chapter 5.4
- Set configuraiton
 - Refer to chapter 6.1
- Switch power supply on
- ✓ Control device in delivery status or after power cut:
 - Red LED blinks continuously twice with a short break of 1.5 sec
- Press RESET for 2 seconds.
- ✓ Red LED blinks continuously.
- Check driving direction of motor:
 - When pressing OPEN, wing has to open and when pressing CLOSE, wing has to close.
 - When driving direction is wrong:
 - Swap motor cables (clamp 7 and 9), check driving direction again.
- Press RESET again for 2 seconds.
- ✓ Red LED lights up permanently, Green LED lights up, when motor is active
- ✓ Drive performs a few runs.
- ✓ LEDs go out.
- ✓ Red LED starts blinking continuously.
- In this state (about 30 seconds) additional complete cycles may be performed. These cycles have to be triggered by user and are optional.
- ✓ After 30 seconds without any function, the LED goes out
- Check desired function.
- In case of malfunction, check electrical connections and configuration
 - Electrical connection, refer to chapter 5.4
 - Configuration, refer to chapter 6.1
 - Repeat initial operation, if necessary
- ✓ Initial operation is completed, when function is correct

Prepare control device

Reset control device



Check function



7 Group control device

7.1 Functional description

The group control device is an additional device, which allows easy control over multiple motor control devices. It simplifies the connection and initial operation of the motor control devices.

Via the DIN-rail connectors (refer to chapter 5.4.3), the group control device controls all attached motor control devices and supplies them with power. The group control device allows dividing the motor control devices in 6 control groups, which can be triggered per group. Also all devices can be triggered together.

Each motor control device is still triggerable directly, if necessary.

CAUTION



Damage of motor control devices and/or DIN-rail connectors by too many connectors in series.

- Connect a maximum of 9 motor control devices via the DIN-rail connectors. Then begin with a new group of control devices.
- When more than 9 motor control devices are used, separate the groups by applying the connector cable (refer to chapter 5.4.4).

Technical data

Parameter	Value
Input voltage	24 VDC
Input voltage tolerance	22,0 ... 26,0 VDC
Reverse voltage protection	No
Width	36 mm Two modular spaces
Number of configurable groups	6 Groups (Open / Close) 1 Collective command (Open / Close)



7.2 Electrical connection

7.2.1 Terminal assignment of the group control device

The group control device provides eight terminal blocks with 3 terminals per terminal block.

At terminals 1, 2 and 3, the power supply is connected.

At terminals 4, 5 and 6, the potential-free, collective control input (0 / Open / Close) is connected.

The potential-free control inputs (0 / Open / Close) for the different groups are connected at terminals

- 7, 8 and 9 for group 1,
- 10, 11 and 12 for group 2,
- 13, 14 and 15 for group 3,
- 16, 17 and 18 for group 4,
- 19, 20 and 21 for group 5 and
- 22, 23 and 24 for group 6.

Klemme	Anschluss	Bild	Bild
1	Ground		
2	+24VDC power supply Feed through to DIN-rail connectors		
3	+24VDC Power supply Group control device only		
4/7/10/ 13/16/ 19/20	Control input ground for corresponding group		
5/8/11/ 14/17/ 20/21	Control input „Open“ for corresponding group		
6/9/12/ 15/18/ 21/22	Control input „Close“ for corresponding group		

Table 6 – Terminal layout of group control device



7.3 Initial operation

7.3.1 Configuration

Assignment of group membership of a motor control device

- Assign group membership with DIP-switches 4, 5 and 6 of each motor control device.
- For encoding, refer to table below:
Group 0 means, motor control device does not belong to any group.
Group 7 means, motor control device belongs to every group.

		Switch	0	1	2	3	4	5	6	7
OFF	ON									
		4	OFF	ON	OFF	ON	OFF	ON	OFF	ON
		5	OFF	OFF	ON	ON	OFF	OFF	ON	ON
		6	OFF	OFF	OFF	OFF	ON	ON	ON	ON

Table 7 – Configuration switch

Assignment of group control device

- Connect push-buttons or actuators of each group at the corresponding terminal blocks.





7.4 Steps during initial operation

- Mount DIN-rail connectors.
 - Refer to chapter 5.4.3
 - Group control device works only, when DIN-rail connectors are used.
- Mount and connect motor control devices.
 - Refer to chapter 5.4
- Mount and connect group control device
 - Refer to chapter 7.2
- Assign group membership of motor control devices.
 - Refer to chapter 6.1
- Perform initial operation for motor control devices.
 - Refer to chapter 6.2
 - You can perform the initial operation per group by using the group control device. Refer to chapter 0
- ✓ Check function.

7.4.2 Application example



Hint

The following example illustrative and does not exempt from reading the entire document.

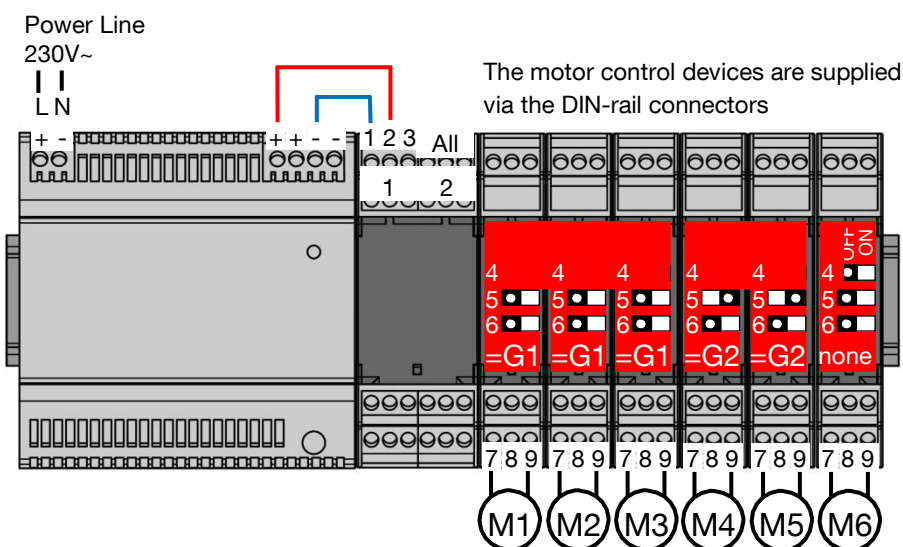

When, for example,...

- ... control input „All“ is set, motors M1, M2, M3, M4 and M5 start to move.
- ... control input „1“ is set, motors M1, M2 and M3 (Group 1) start to move.
- ... control input „2“ is set, motors M4 and M5 (Group 1) start to move.
- M6 can only be triggered by its own inputs, never at any time by the group control device.



7 Group control device

7.5 Extended functions

For ease of initial operation and service, the group control device provides extended functions.

The front panel of the group control device shows multiple LEDs “DC ok“, “Info“ and “Group 1“ to “Group 6“, to display the status of the device.

In addition, two keys “T1“ and “T2“ are available for basic control functions.

7.5.1 Standby mode and normal operation

After power is applied, the group control device goes into standby mode.

The green LED “DC ok“ lights up, when DC voltage is applied and when it stays within the tolerated range.

In this mode of operation, the group control device forwards input commands to the corresponding motor control devices. For monitoring purposes, each LED, dedicated to a group, lights up, when an input for these group becomes active. The group LED also lights up, while any motor control device, belonging to this group, is active.

7.5.2 Manual control mode

The user can control the motor control devices manually by using the group control device.

- | | |
|-------------------------------------|---|
| Activate manual control mode | <ul style="list-style-type: none">➤ Group control device is in standby mode.➤ Press “T1“ for at least 2 seconds.✓ LED “Group 1“ blinks once per second.<ul style="list-style-type: none">→ 60 seconds after the last activity, the group control device goes back into standby mode. |
| Choose active group | <ul style="list-style-type: none">➤ Choose active group by repeatedly pressing „T1“, until desired group is indicated.➤ Press “T1“ for at least 2 seconds, when the LED of the group, you want to control, blinks.✓ LED of selected group blinks fast. |
| Send control command | <ul style="list-style-type: none">➤ Press “T1“, to send command „Close“.➤ Press “T2“, to send command „Open“.✓ Confirmation: LED of selected group lights up for about 2 seconds.<ul style="list-style-type: none">→ Motor activity of any group is not indicated in this mode of operation. |
| Leave manual control mode | <ul style="list-style-type: none">➤ Press “T2“ for at least 2 seconds, to return to the group selection menu.✓ LED of selected group blinks once per second.<ul style="list-style-type: none">→ A new group can be chosen. Refer to „Choose active group“.➤ Press “T2“ again for at least 2 seconds, to return to standby mode.✓ Group LED goes out (unless motor control devices of this group are still active). |



7.6 Initial operation in groups

The group control device allows performing the initial operation for multiple motor control devices in groups.

WARNING



Moving wing

Danger of injury by squashing, shearing or collision, caused by moving wing.

- Wing moves independently during initial operation.
- Keep danger area clear during initial operation.

- Group control device is in standby mode.
- Press “T2” for at least 2 seconds.
- ✓ LEDs “Info” and “Group 1” blink once per second.
 - 60 seconds after the last activity, the group control device goes back into standby mode.
- Choose active group by repeatedly pressing „T1“, until desired group is indicated.
- Press “T2” for at least 2 seconds, when the LED of the group, you want to control, blinks.
- ✓ LED of selected group blinks fast.
- ✓ LED “Info” lights for about 3 seconds constantly.
- ✓ Motor control devices of selected group start initial operation.
 - Steps of the initial operation are described in chapter 6.2.
 - Initial operation of each motor control device must be supervised separately. There is no feedback on the success of the initial operation to the group control device.
 - Initial operation of each motor control device can also be done on the regular way (refer to chapter 6.2).
- ✓ LED “Info” and LED of selected group blink once per second.
- Perform further initial operations according to the description above, or leave configuration mode.
- Press “T1” for at least 2 seconds, to leave configuration mode.
- ✓ LEDs go out (unless motor control devices of this group are still active).

Activate configuration mode

Choose active group

Leave configuration mode

7.6.1 Error mode

When the group control device discovers any error, it changes into error mode. Particularly, when the supply voltage falls under a critical value of less than 12VDC.

In this mode, all control inputs and the communication with the motor control devices is disabled. The error mode is displayed by a fast blinking of LED “Info”.

As soon as the source of malfunction is cleared, the group control device goes back into standby mode.



www.baier-gmbh.de

7

Group control device

We provide you with approved quality:

Baier GmbH
Reiersbacher Straße 28
D-77871 Renchen-Ulm

Tel. +49 (0) 78 43 / 94 76 - 0
Fax +49 (0) 78 43 / 94 76 - 33

info@baier-gmbh.de
www.baier-gmbh.de

